

# Application Success Stories

## Flexiform replace two booths with latest Gema BA04 System

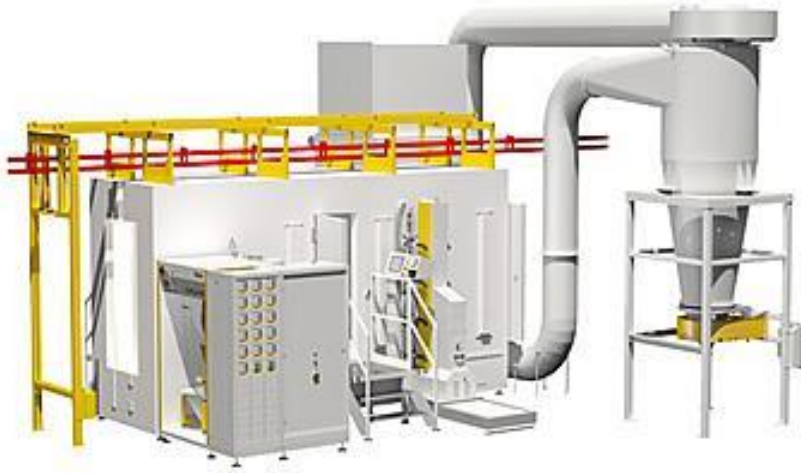

flexiform

Big reduction in  
powder use and  
waste

Increased plant  
efficiency

Faster colour  
change and cleaning

# Application Success Stories

## Layout

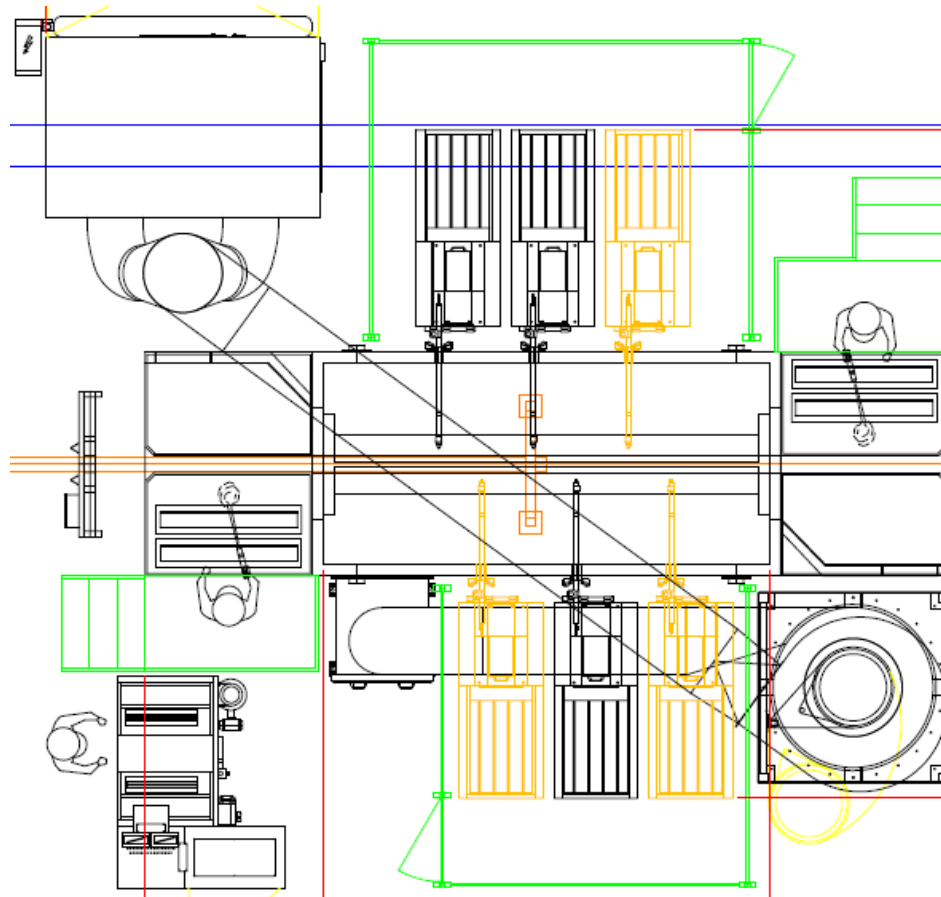

# Application Success Stories

## Installation Key Data

**Parts:** Office Furniture

**Production data:**

- 2400mm high
- 650mm wide
- 4.1 metres per min

**System Type:**

- MagicCompact® EquiFlow booth
- OptiCenter® OC03 with AP01
- 20,000m<sup>3</sup>/h
- 27 OptiGun GA03 automatic guns
- 2 manual stations
- MagicControl CM30 control system
- Product recognition
- X & Y reciprocation



# Application Success Stories



## Company Profile:

Flexiform, manufacturers of Office Furniture and Asgard Secure Steel Storage, have been operating in West Yorkshire for over 40 years and pride themselves on their reputation for high quality



functional business furniture and storage solutions. Continuous improvement and efficiency is at the heart of Flexiform's business and forms a foundation for everything they do, as a part of an ongoing investment



programme they have recently installed a new automatic Gema Magic Compact powder coating plant.

# Application Success Stories

## **Simon Hoskins, Head of Operations, discusses the investment and their reasons for the upgrade:**

“The previous paint plant had served the business for many years and produced a high-quality finish on thousands of different Flexiform products, however, we were looking at overall production efficiency and it became clear that a new powder coating plant would deliver many benefits both in efficiency and sustainability, as an ISO 14001 accredited business we take our environmental impact seriously. We approached the market and spoke to various suppliers before deciding to partner with Gema, we wanted a system that will work for us for many years so latest technology and innovation was very important, Gema demonstrated that their latest pump technology was going to deliver exactly what we wanted.

The plant was commissioned and in full production at the end of summer 2017, since then all of the benefits we expected have been realised. The booth height was increased with additional guns and reciprocators installed, this has allowed an increase in the number of products we can process through the booth, this has significantly improved our throughput and removed a previous bottleneck in the paint area, this is great news for our customers and despatch department. One of the most impressive benefits from the system is the reduction in powder use and overall waste, the new gun technology charges and applies the powder more efficiently as a result we are achieving our usual high-quality finish with less powder due to a more consistent overall coating thickness. The powder extraction system reclaims over sprayed powder automatically, this has reduced powder waste by around 60%, this not only represents a big cost saving but has also massively reduced our annual waste removal. Our operators now spend considerably less time during colour change and clean down, the control system has given much more flexibility in the way we apply the powder to suit specific products.

Simon concluded “the Gema plant has more than lived up to our expectations and we expect a return on investment within 2 years. In short, the new plant is more efficient, easier to operate and better for the environment, so better for us and our valued customers.”