

Application Success Stories

Quality Powder Coating QPC AB Job Coater



Flexibility

Efficiency

Economics

Application Success Stories

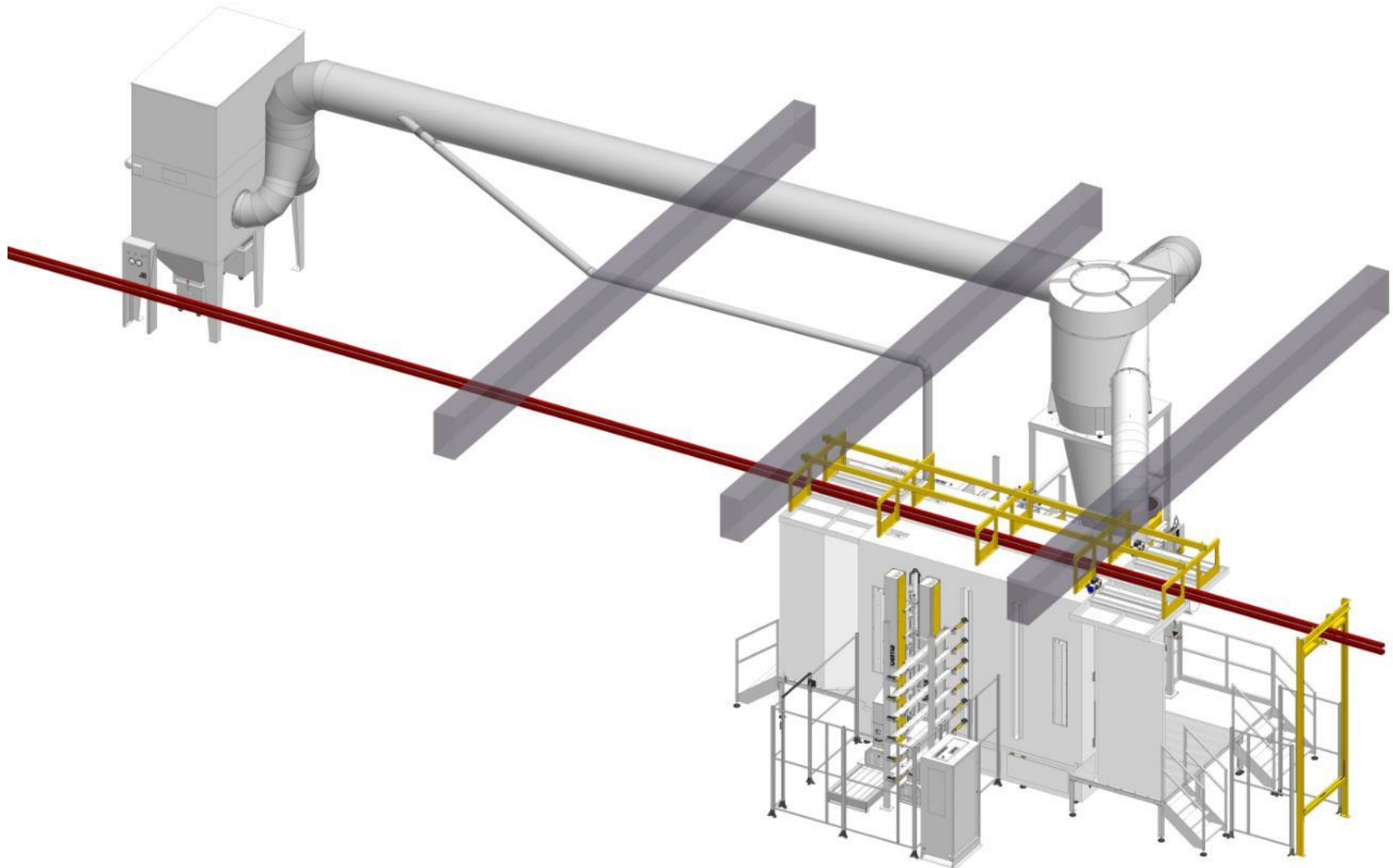

Application Success Stories

Installation Key Data

Parts:

Various, Job Coating

Parts size:

H 2'200 mm

W 1'000 mm

L 7'000 mm

Scope of delivery:

1 x OptiFlex AS06 / 22P

20 x OptiGun GA03P-1300 automatic gun

2 x OptiSelect®2 GM03 manual gun

1 x ZA07-23 reciprocator with XT10

6 x Gun axis UA04 with 2 x Laser Scanner

1 x Control system ICS04/CM-30 MagicControl

1 x OptiCenter OC03 with 22 x application pump AP01

1 x MagicCompact EquiFlow booth system



Application Success Stories



Eco-friendly powder coating that meets strict requirements for corrosion resistance is the main task of Quality Powder Coating, QPC, in Nässjö, Sweden. In the modern plant are parts powdered with or without primer, according to the corrosion requirements of the customers from engineering industry, automotive industry, construction and public areas.

To fulfil these tasks today and in the future, QPC is always using the latest technical solutions in powder coating. When the 10 years old primer coating booth had to be replaced, QPC started to look for a

color change solution with highest flexibility, efficiency and economics. During an open day with a Swedish Company they learned about the Gema powder application pump AP01. The tests in the Gema laboratory in St. Gallen convinced the Production Managers of the benefits of this system and the easy handling of the OptiCenter.

During the tests, Gema introduced their new gun axis system UA04. This system enables the individual vertical positioning of 6 automatic guns in a range up to 300 mm in the new booth at QPC. This is for QPC the ultimate solution to coat

complex parts in depth and the inner sides of electrical cabinets. QPC decided to put this new product from Gema in operation as the first user in Scandinavia. Finally, the PCC mode of the gun controls has become the key to improve the quality in metallic coating and cabinet coating.

Today, the new color change system by Gema enables QPC to extend the offer of solutions for their customers and to work more reliable, more flexible and more economic. So much, that the top coat line will be replaced soon by an identical system.

Application Success Stories



Application Success Stories

