

# Application Success Stories

## Mikropor A.Ş. Booth Application



Higher Flexibility

Less powder  
consumption

More Reliability

# Application Success Stories

## Layout

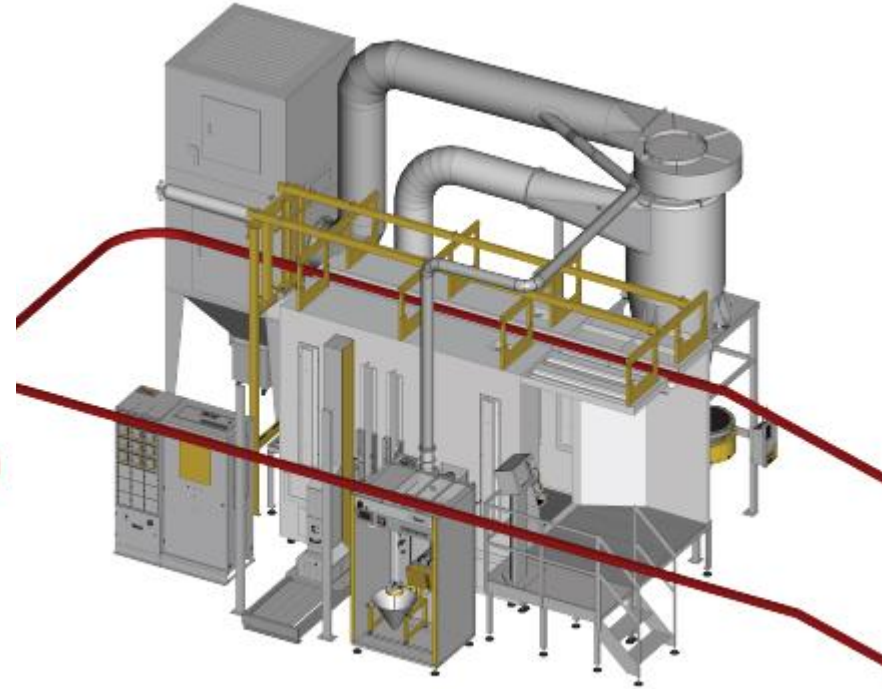
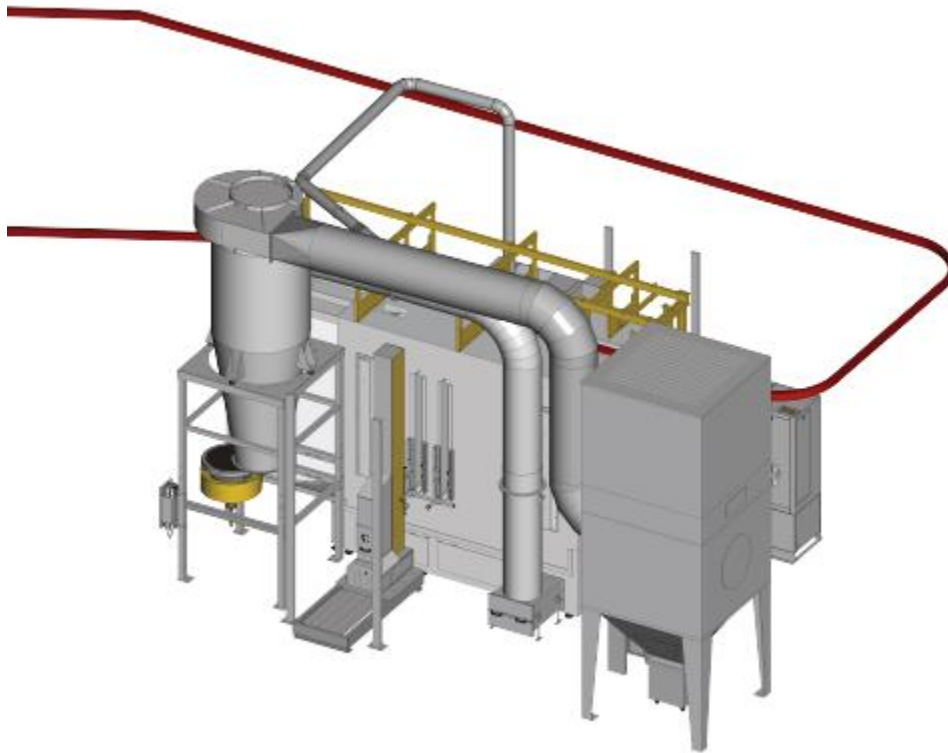

# Application Success Stories

## Installation Key Data

**Parts:** Filtration Products

**Part Size:** H 1'200 mm  
B 350 mm

**Conveyor Speed:** 2,0 m/min

### **Scope of delivery:**

- 1 x OptiFlex® Automatic AS06 / 6P
- 2 x Reciprocator ZA07-18 / XT120-10
- 1 x MagicControl CM30 system control
- 1 x MagicCompact® EquiFlow® BA04 booth 12'000 cbm/h
- 1 x OptiCenter® OC02 with ultrasonic sieve
- 6 x OptiFlow Injector IG06-P





# Application Success Stories



Mikropor is a leading worldwide provider of quality filtration and purification products for air, gas and liquid applications. It is the market leader in Turkey and one of the well-known company in Europe and USA.



As being an efficient dedicated company, Mikropor is investing in more flexible, economical and robust systems.

Investment of a new powder booth system has been given in 2016 and GEMA Switzerland products has been elected.



At the very beginning of 2017 Gema Powder Booth system has been implemented and resulted in faster color changes, less powder consumption and improved quality to Mikropor products.