

Application Success Stories

Schneider Electric – (ex SAREL)

- **ERGONOMIC WORKSTATIONS**



ERGONOMICS

HEALTH & SAFETY

ATEX compliant

Application Success Stories

Layout

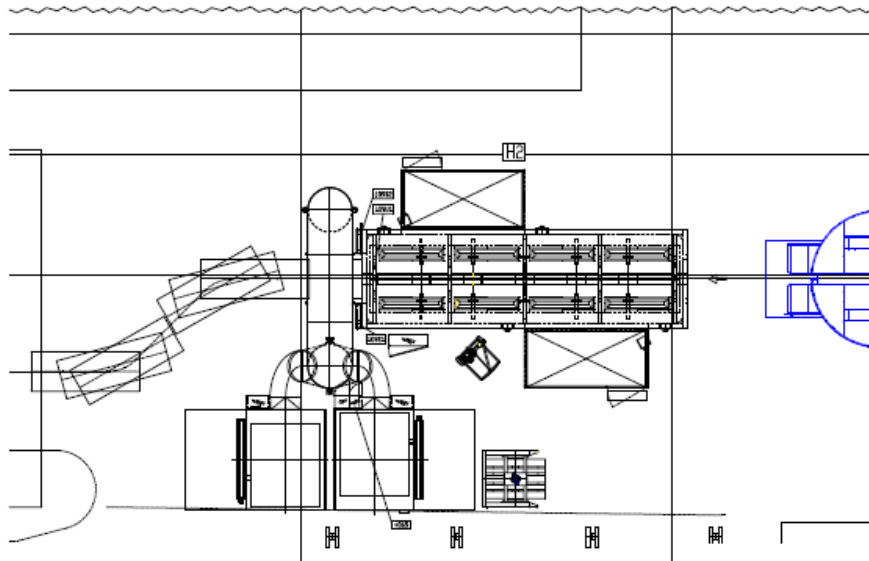
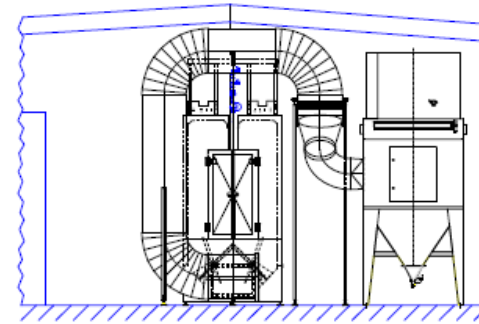
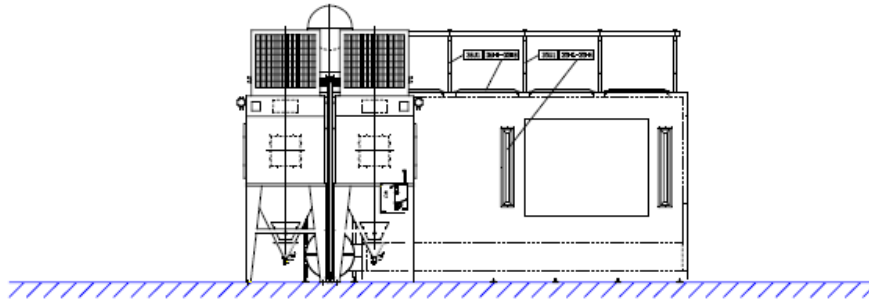

Application Success Stories

Installation Key Data

Parts : Metallic components for electrical protections

Parts size :

- H 1'600 mm
- L 2'200 mm
- D 800 mm

Conveyor speed : variable m/min

Scope of Delivery

- 1 x Magic Plus manual booth
- 1 x manual gun OptiFlex®2 Q +
- 1 x manual gun unit Wall Kit
- 2 x filters 16'000m²/h
- 1 x WPS systems with Big-Bag
- 2 x lift tables
- 1 x fire protection system



Application Success Stories

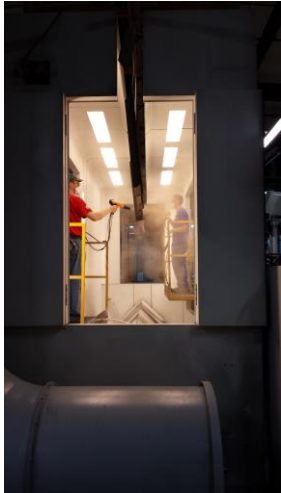

From 1956, the vocation of the company Sarel is to develop, produce, and sell envelops for the physical protection and the installation of industrial automatism equipment, electrical distribution as well as VDI Networks. In 2011, Sarel joined Schneider Electric and became stronger on its markets. Historically Gema's customer, Sarel requested us to replace existing manual booths being technologically too old but

offering a greater application ease to the manual operators. The challenge was to maintain indeed improve the application comfort, plus to comply with the ATEX regulation and meanwhile to get a powder dust free environment.

To fulfill those requirements, the solution has been a **Magic Plus manual booth**, with two large lateral openings equipped with **2 lift platforms** and a **double OptiFlex®2Q**.

The booth concept offers a comfortable manual application environment while the OptiFlex®2 Q complied with a quick color change time and clean operation process. The entire installation upgrade with a proper ventilation, a new fire protection system and an up to date manual application offers to Sarel the ATEX regulation compliance and a full operator's acceptance.