

Application Success Stories

Rainford Solutions – Electrical Enclosures



Fast Colour Changes

Improved Finish Quality
and Process Control

Advanced Automation

Application Success Stories

Installation Key Data

Parts: Electrical Enclosures

Part size:

H 1'500mm
W 800mm

Conveyor speed:

v_{\max} 1-1.6 m/min

System Type:

- 1x MagicCompact® EquiFlow®
- 1x OptiCenter® All-in-One
- 1x Cyclone and after filter 16'000m³/h
- 8x OptiGun® automatic gun
- 1x manual stations
- 1x OptiFlex® Pro B
- 1x MagicControl 4.0 control system
- 1x Product recognition
- 2x X & Y reciprocation



Application Success Stories

Layout

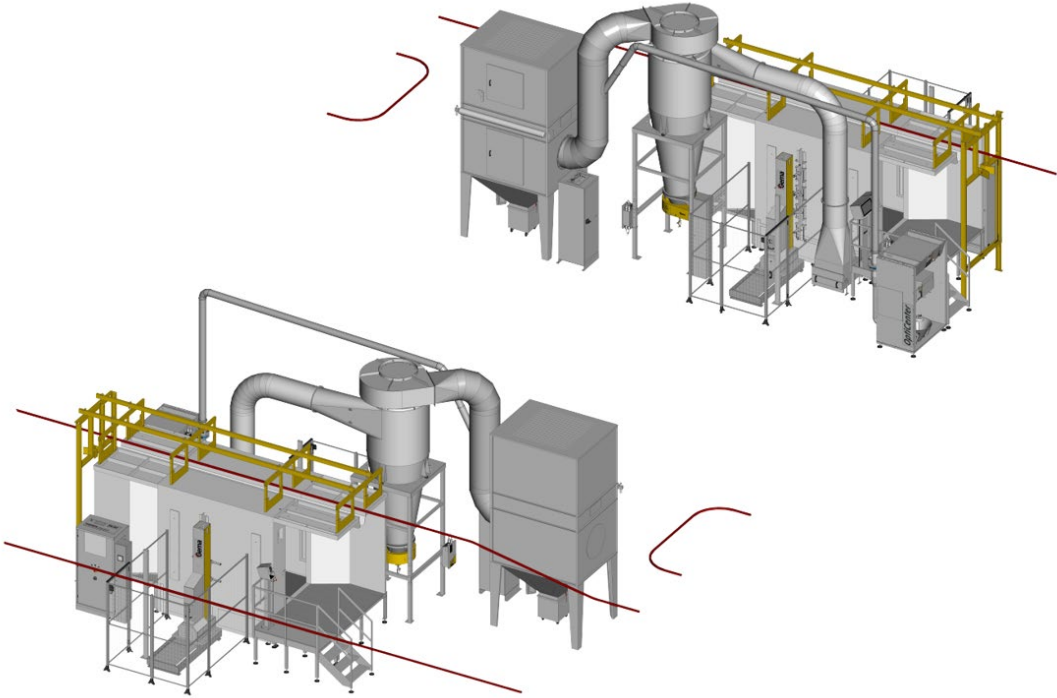

Application Success Stories

Rainford Solutions LTD is delighted to announce circa 800K capital investment in a new, in-house electrostatic powder painting facility has just been completed at their facility in St Helens. The new plant will offer significant benefits in lead time reduction, capacity, speed, reliability, and powder coating performance.

The new 950m² powder coating facility will house two advanced powder coating processes, line one comprising of a fully automated on-line solution, with an advanced 4 stage pre-treatment wash and encompassing the latest fast colour change powder application technology from Gema. This line will be supporting small to large production volumes with a second semi-automated bespoke line supporting prototype and project work.

A significant part of this investment is with Gema, who have supplied and supported the installation of one of their advanced fast colour change solutions pictured below. Mark Corns, Operations director at Rainford Solutions went on to explain 'After a comprehensive market study it was clear that the Gema was the natural fit for Rainford Solutions. Having visited several installations, Gema's Magic Compact delivered the benefits we were looking to achieve, its robust quality and more importantly after sales service provision were

also key parts of our decision making process around this investment. The professionalism and knowledge around their products through every step of the journey has been superb, from technical sales, design, installation and commissioning teams it has been a pleasure to deal with Gema and this further reinforced that we have made the right decision to select the industry leaders as our partner.'

Paul Gamble, Paint Shop Manager at Rainford Solutions added 'Having supported the procurement process and overseeing the installation of the new system we have been impressed with the professionalism, quality, communication and support throughout the journey with Gema. We put the Magic booth through its paces conducting multiple fast colour changes and experienced the quality off the line within hours of going live, we are delighted with the results. The booth system is equipped with fast colour changing technology along with recycling cyclone, automatic reciprocating guns and two manual touch-up platforms and also benefits from Gema's latest Industry 4.0 offerings. It's the perfect match to meet our demands of high-quality finished products, high degrees of automation, production efficiency and environmentally sound.'

Gema's latest OptiCenter feeds the system with powder and incorporates all-in-one suction pump

technology. The OptiSpeeder hopper features include powder level detection, and a highly automated cleaning process. These features have all been engineered to make the system as accurate and reliable as possible, whilst keeping the physical footprint low and need for human interaction to a minimum.

Leon Hogg, General Manager UK for Gema, explained 'It was clear during the evaluation stages that the team at Rainford Solutions were keen to invest in the very latest innovations that deliver quality and performance benefits to their existing and future customers. With the high demand for quality, repeatability and efficiency we quickly arrived at the Magic Compact fast colour change booth, a system that provided the perfect strategic fit when it comes to matching the level of performance and efficiency Mark Corns and his team were looking for. This investment in the very latest technology puts Rainford Solutions at the forefront of its industry as a provider of premium finished products. Want to see how Gema can assist with your powder coating requirements? Get in touch with their friendly team today on 01202 763942 or e-mail uk.sales@gema.eu.com