

# Application Success Stories

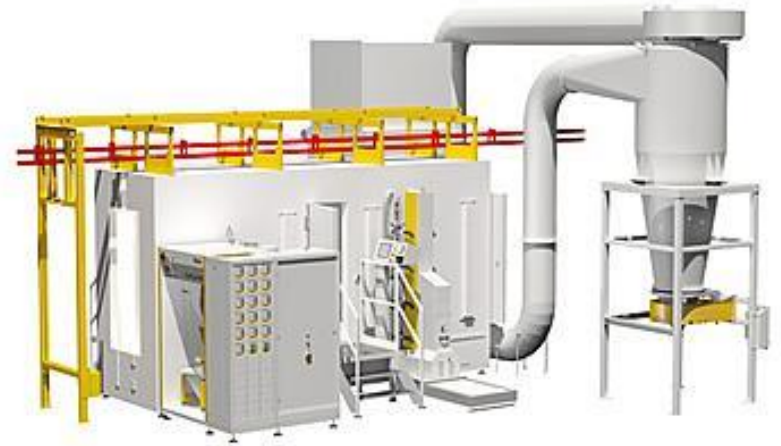

POWDERTECH  
SURFACE SCIENCE



**Powdertech invest in the latest Gema powder coating technology**

Improved coating  
quality

Increased plant  
efficiency

Reduction in powder  
waste

# Application Success Stories

## Layout

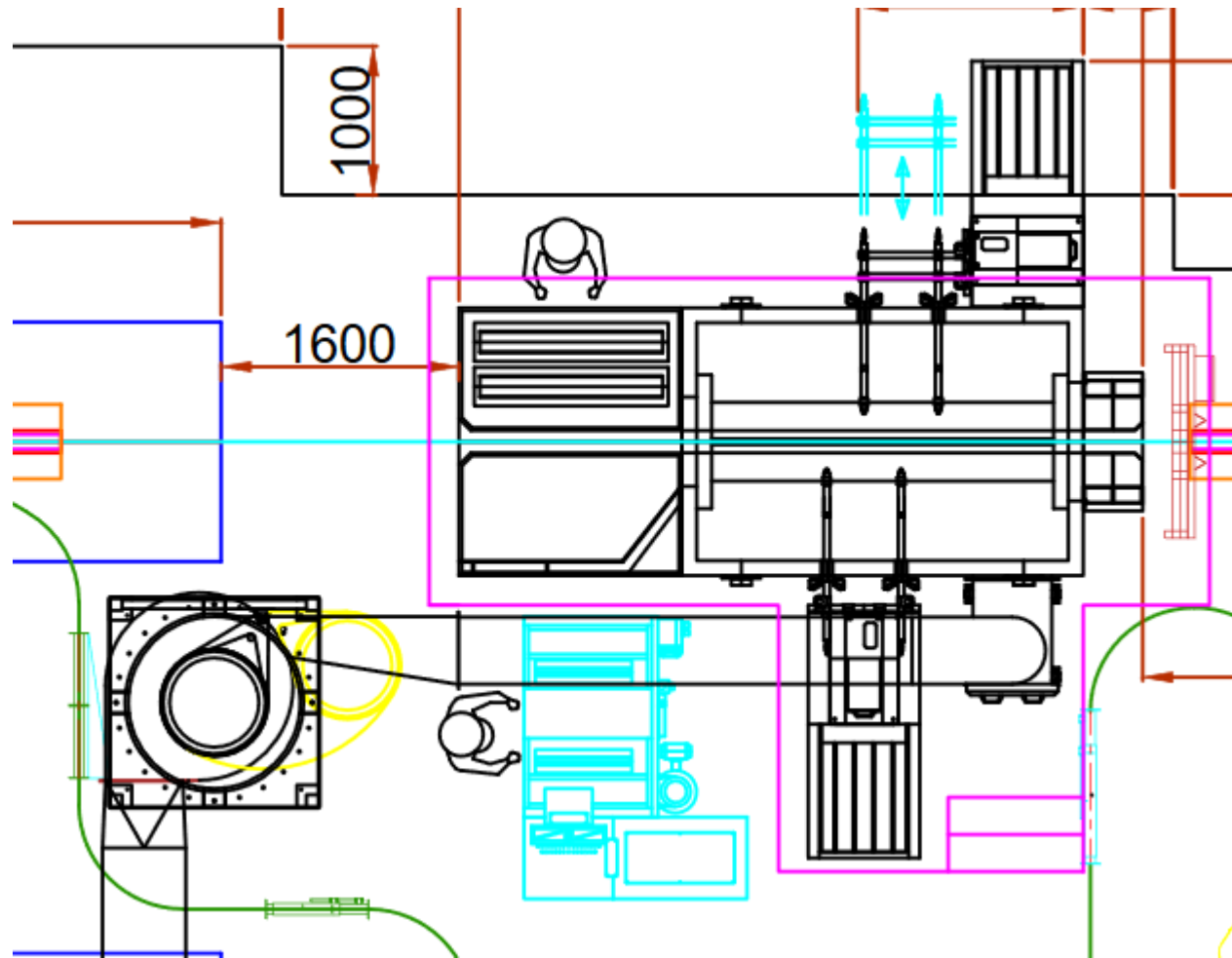

# Application Success Stories

## Installation Key Data

### **Parts:**

Extrusion

### **Production data:**

- 1500mm high
- 500mm wide
- 2 meters per min

### **System Type:**

- Magic Compact
- AP01 Pump Technology
- 12,000m<sup>3</sup>/h
- 4 Automatic guns
- 1 manual station
- OptiCenter©
- CM30 control system
- Product recognition
- X & Y reciprocation



# Application Success Stories



## **Company Profile:**

Powdertech Surface Science are experts in the application of chrome-free pre-treatments and powder coatings for lightweight alloy materials, in the automotive, aerospace, architectural and other

specialised industries. We have been in business for over 30 years and operate at the forefront of our industry. What drives us to succeed is delivering a high quality product that exceeds our customers' expectations and is of the very

highest quality finish. We have strong track record of excellence and are proud to be associated with many UK and overseas OEM companies.

# Application Success Stories

## **Powdertech Director James Grant discusses their investment:**

“Powder coating is a core part of our business and we have been providing our services to clients for over 30 years. For us it is vital that we are offering state of the art facilities as part of this service, so when we decided to replace one of our current coating lines with a brand new system, Gema were the obvious choice for the powder coating plant.

We started with a blank canvas, removing every part of the old line which left us with a compact area in which to install a new, fully conveyerized coating system which could coat four metre lengths. We were aware that we were asking a lot of the project members, trying to squeeze everything we needed into the space available. Gema were very accommodating in this and tailored their design to successfully house the Magic Compact booth, OC03 paint station, CM30 control panel, cyclone and after filter around the oven and conveyer.

By specifying the Gema magic eye system, automatic X and Y axis reciprocators and also the latest AP01 pumping system, we believe that we have all of the tools to allow us to achieve our key objectives:

- To coat the various products we do automatically, with reduced manual touch up
- Reduce powder waste
- Improve consistency of powder application
- Vastly reduce colour change times

With the installation of the latest Gema powder coating technology, we are well placed to service the needs of our current, and new, clients going forwards.

We are in a demanding industry and our commitment to investment in new plant shows our drive to not only meet, but to exceed, the needs of the industry today and in the years ahead”.

